

code **ST10** | project **A25** | release **C**

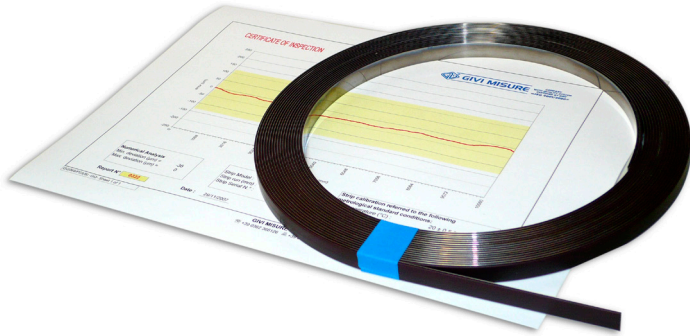

GENERAL FEATURES

- Incremental magnetic band composed of a plastoferrite tape with 1+1 mm pole pitch, supported by a stainless steel carrier on which a double-sided tape is pre-mounted, for an extremely quick sticking and an easy fixing.

MP 100

Pole pitch	1+1 mm
Accuracy grade	± 20 µm standard version * ± 5 µm special version *
Width	10 mm
Thickness	1.3 mm without double-sided tape + 0.1 mm with double-sided tape
Maximum length	75 m
Linear thermal expansion coeff.	10.6 x 10 ⁻⁶ °C ⁻¹ T ref. = 20 °C ± 0.1 °C
Bending radius	130 mm _{MIN}
Operating temperature	-20 °C ÷ 70 °C
Storage temperature	-20 °C ÷ 80 °C
Magnetic band weight	65 g/m
Cover weight	25 g/m

* The declared accuracy grade of ± X µm is referred to a measuring length of 1 m.

INSTALLATION AND HANDLING

- Protect the band from external magnetic fields. Contact with any permanent magnet can irreparably damage the magnetic band.
- Do not stress mechanically the magnetic band. The magnetic band has to be rolled always in the same way (plastoferrite towards the outside), with a minimum bending radius of 130 mm.
- It is not possible to apply any protective cover on the magnetic band MP 100.
- Clean carefully the fixing surface from oil, grease or any kind of dirt, using trace-free solvents.
- Place the band maintaining it aligned with the reader head. Make sure the magnetic part is facing the sensor.
- The maximum adhesion will be achieved after 48 hours from sticking.

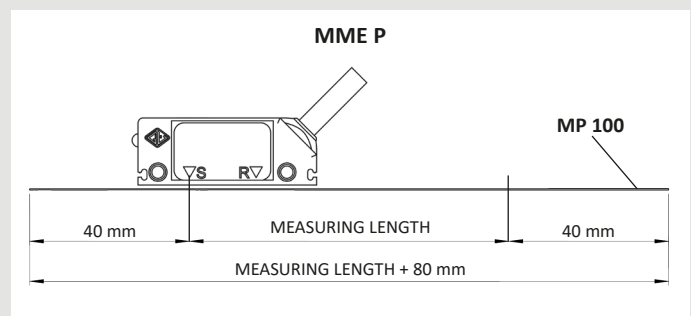
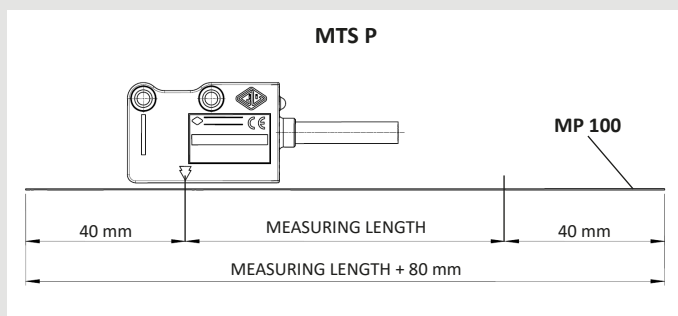

IMPORTANT: To guarantee the system accuracy, the magnetic band has to be 80 mm longer than the measuring length of the machine (40 mm for each side). During mounting, the magnetic band has to be adequately centered on the measuring length.

ORDERING CODE

Example MAGNETIC BAND **MP 100 01000 STANDARD ACCURACY**

Model	Length in mm	Accuracy grade
MP 100	01000 = 1 m 20000 = 20 m	Standard accuracy Special accuracy

Without prior notice, the products may be subject to modifications that the Manufacturer reserves to introduce as deemed necessary for their improvement.